

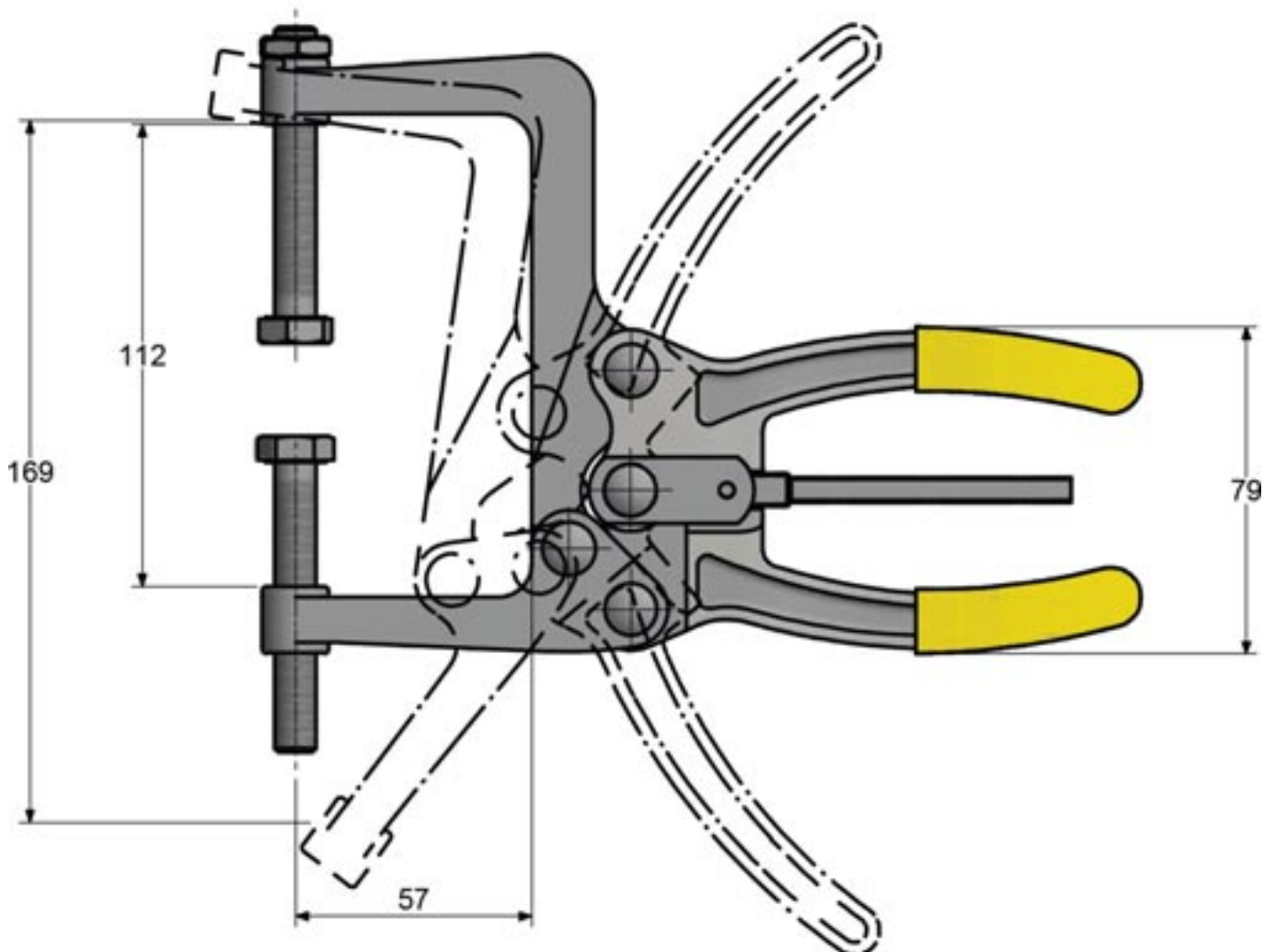

Material	Schwerer Stahl Gehärtete Stifte und Buchsen
Oberfläche	verzinkt
Im Lieferumfang	10x70 mm Spindeln
Max. Haltekraft	545 daN
Gewicht	1.1 kg
Hub	-
Spanndruck	170 daN

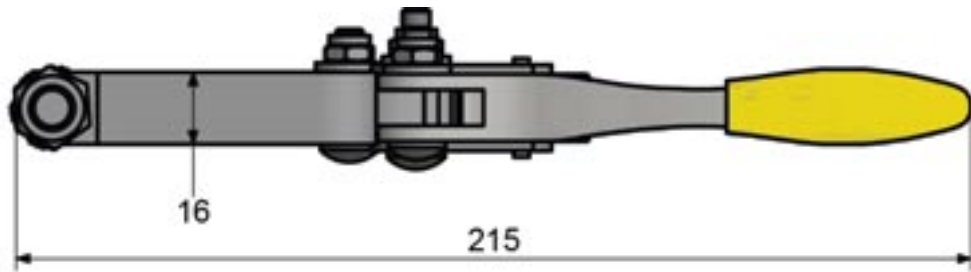

ZANGENWIRKUNG