

# Horizontalspanner T 2-.. U



## U-Arm Standardfuß

### Optionen:

- \* Feststellarretierung „A“ erhältlich für T2-37 U
- ° Rostfrei „E“ erhältlich für T2-05 U, 13 U, 17 U, 27 U, 37 U

Lieferung ohne  
Andrückschraube

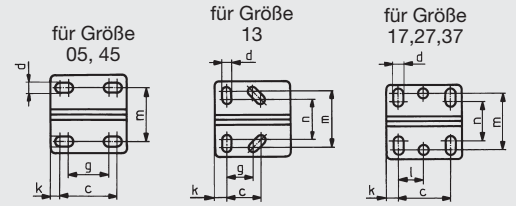
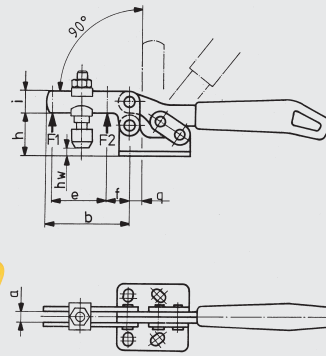
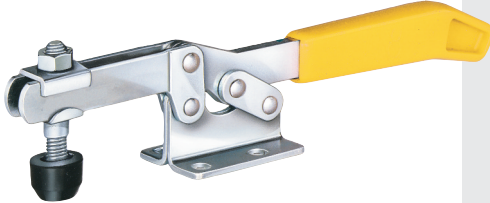

Typ	Spannkraft		Höhe	Breite	hw	Spann- schraube	Gewicht g
	F1 [kN]	F2 [kN]					
T 2-05 U°	0,25	0,40	23	86	-5 - 2	M4x25	35
T 2-13 U°	0,80	1,10	30	130	-4 - 3	M5x30	105
T 2-17 U°	1,00	1,20	44	176	-3 - 6	M6x35	185
T 2-27 U°	1,80	2,50	48	221	-1 - 11	M8x45	320
T 2-37 U*°	2,00	3,00	74	293	-6 - 23	M8x65	700
T 2-45 U	3,00	5,00	71	338	-1 - 25	M8x65	1080

Typ	a	b	c	d	e	f	g	h	i	k	l	m	n	q
T 2-05 U	4	26	16,0	4,6	11	10	11,2	15	7	5,0	-	15,6/16,0	-	2
T 2-13 U	5	40	15,0	4,8	26	11	13,0	20	10	5,5	-	22,0	18	5
T 2-17 U	6	64	26,0	5,5	35	22	-	25	13	6,0	12,7	29,0	20	0
T 2-27 U	8	72	25,5	6,5	44	22	-	33	15	7,0	-	29,0	23	8
T 2-37 U*	10	111	41,0	8,5	66	34	-	44	20	8,0	20,5	43,0	29	1
T 2-45 U	10	121	41,5	8,5	78	30	-	46	25	12,5	-	41,5	-	9

Lieferumfang: mit Zubehör zur Befestigung der  
Andrückschraube

# Horizontalspanner T 2-.. UB



## U-Arm Befestigungsfuß senkrecht

### Optionen:

- \* Feststellarretierung „A“ erhältlich für T2-37 UB

Lieferung ohne  
Andrückschraube

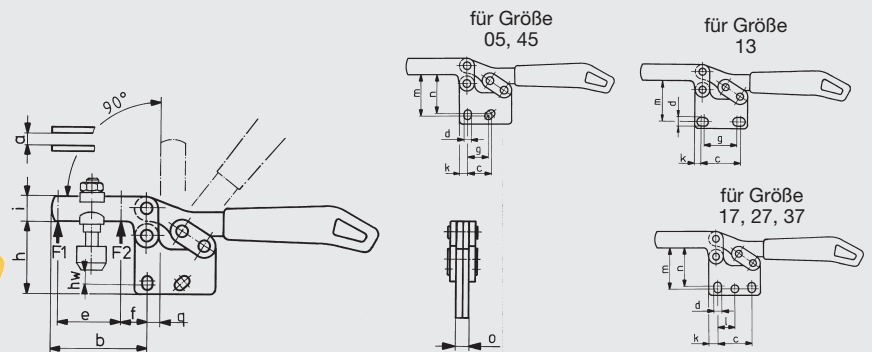
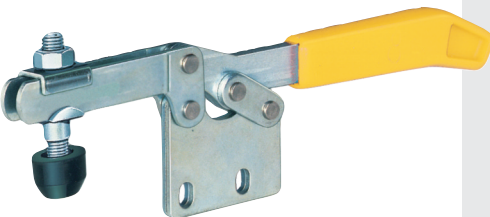

Typ	Spannkraft		Höhe	Breite	hw	Spann- schraube	Gewicht g
	F1 [kN]	F2 [kN]					
T 2-05 UB	0,25	0,40	33,0	86	0 - 7	M4x25	35
T 2-13 UB	0,80	1,10	42,0	130	3 - 10	M5x30	105
T 2-17 UB	1,00	1,20	59,0	176	7 - 16	M6x35	185
T 2-27 UB	1,80	2,50	63,5	221	8 - 20	M8x45	320
T 2-37 UB*	2,00	3,00	96,0	293	9 - 38	M8x65	700
T 2-45 UB	3,00	5,00	91,5	338	13 - 37	M8x65	1080

Typ	a	b	c	d	e	f	g	h	i	k	l	m	n	o	q
T 2-05 UB	4	26	16,0	4,6	11	10	11,2	24	7	5,0	-	20	-	3	2
T 2-13 UB	5	40	15,0	4,8	26	11	13,0	32	10	5,5	-	27	25	5	5
T 2-17 UB	6	64	26,0	5,5	35	22	-	40	13	6,0	12,7	35	31	5	0
T 2-27 UB	8	72	25,5	6,5	44	22	-	48	15	7,0	-	42	39	6	8
T 2-37 UB*	10	111	41,0	8,5	66	34	-	66	20	8,0	20,5	59	52	8	1
T 2-45 UB	10	121	41,5	8,5	78	30	-	66	25	12,5	-	58	-	10	9

Lieferumfang: mit Zubehör zur Befestigung der  
Andrückschraube

Technische Änderungen vorbehalten.